

Channels Not On Plot
1001 - House Lights

LINESET SCHEDULE

41	Cyclorama	30'-6"
40	EMPTY	29'-0"
39	EMPTY	29'-0"
38	EMPTY	28'-6"
37	EMPTY	27'-0"
36	4th Electric	27'-2"
35	EMPTY	26'-6"
34	EMPTY	25'-0"
33	Full Stage Black	25'-2"
32	4th Electric	24'-6"
31	EMPTY	23'-0"
30	4th Legs	23'-2"
29	4th Border	22'-6"
28	EMPTY	22'-0"
27	EMPTY	21'-2"
26	EMPTY	19'-0"
25	Speakers	19'-2"
24	EMPTY	18'-6"
23	3rd Electric	17'-0"
22	EMPTY	17'-2"
21	3rd Legs	16'-6"
20	3rd Border	15'-0"
19	EMPTY	14'-6"
18	EMPTY	13'-0"
17	EMPTY	13'-2"
16	EMPTY	12'-6"
15	EMPTY	12'-0"
14	WHS Walls	11'-2"
13	2nd Electric	9'-0"
12	EMPTY	9'-2"
11	2nd Legs	8'-6"
10	2nd Border	7'-0"
09	Closet Door	7'-2"
08	EMPTY	6'-6"
07	EMPTY	5'-0"
06	EMPTY	5'-2"
05	1st Electric	4'-6"
04	EMPTY	3'-0"
03	EMPTY	3'-2"
02	1st Legs	2'-6"
01	EMPTY	2'-0"
	Grand Curtain	0'-0"
	Block & Fall Border	0'-2"

LIGHTING INSTRUMENT/ACCESSORY KEY

SYMBOL	INSTR./ACC.	LOAD	QTY.
	Altman PAR64 MFL	1000W	(9)
	Altman PAR64 WFL	1000W	(36)
	ETC Source Four PAR WFL	575W	(4)
	ETC Source Four 10°	575W	(2)
	ETC Source Four 19°	575W	(75)
	ETC Source Four 26°	575W	(22)
	ETC Source Four 36°	575W	(32)
	Altman T-3 Cyc 3-Circuit	1500W	(10)
	ETC ColorSource PAR Deep Blue	120W	(6)
	Chauvet Rogue R1 Wash	161W	(1)
	Vari-Lite VL2500 Spot	700W	(1)
	Rosco I-Cue	17W	(1)
	City Theatrical DMX Iris	25W	(1)
	Le Maître MVS Hazer	300W	(19)
	HES F-500 Fog Generator	1450W	(30)
	Template		(19)
	Top Hat		
	Half Hat		

COLOR & TEMPLATE SUMMARY

Color	Size	Count	Color	Size	Count
G250	10"	35	R378 & R119	6.25"	18
G645	8 1/2" x 13"	10	R314 & R119	6.25"	20
L139	6.25"	4			
L200 & R119	6.25"	1	Template	Size	Count
L201 & R132	12"	1	G208	A	1
L201 & R132	6.25"	2	G376	A	1
L716	10"	35	G579	A	1
R02 & R08	6.25"	2	G585	A	2
R02 & R132	6.25"	1	R7725	B	2
R21	10"	35	R7724	B	16
R27	8 1/2" x 13"	10			
R34 & R119	6.25"	18			
R39 & R41	12"	1			
R51 & R119	6.25"	6			
R55 & R119	6.25"	20			
R57 & R119	6.25"	6			
R117	7.5"	6			
R305 & R119	6.25"	4			
R318 & R119	6.25"	16			

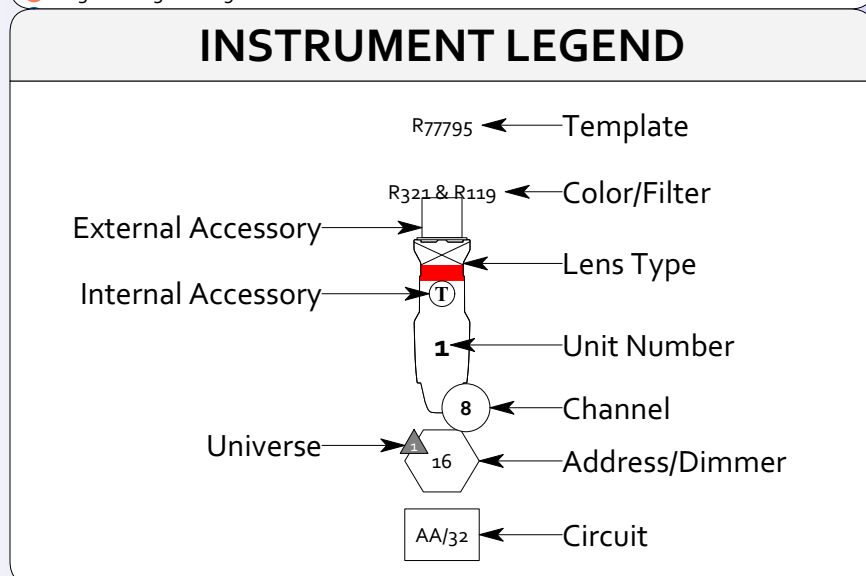

- ### LIGHTING NOTES
- Please direct all lighting questions to the Lighting Designer or Lighting & Projections Supervisor.
 - Exact placement of F-500 Fogger and MVS Hazer TBD at Load-In.
 - Units on BALCONY RAIL may need to be yoked onstage.
 - Ch 456 will use variegated gel; please consult with Designer.
 - Please have 6x7.5" cuts each of R116 and R118 on hand for Load-In.
 - Please circuit cyc lights in order and patch as 3ch Generic RGB.
 - ETC ColorSource PAR Deep Blue is in 6ch [Direct] mode.
 - Chauvet Rogue R1 Wash is in 3ch mode.
 - Rosco I-Cue is in ch [168] mode.
 - Le Maître MVS Hazer is in 1ch mode.

ALEX J. ALEGRIA
LIGHTING DESIGN

THIS DRAWING REPRESENTS VISUAL CONCEPTS AND CONSTRUCTION SUGGESTIONS ONLY. THE DESIGNER IS UNQUALIFIED TO DETERMINE THE STRUCTURAL OR ELECTRICAL APPROPRIATENESS OF THIS DESIGN AND WILL NOT ASSUME RESPONSIBILITY FOR IMPROPER ENGINEERING, CONSTRUCTION, HANDLING, OR USE. ALL MATERIALS AND CONSTRUCTION MUST COMPLY WITH THE MOST STRINGENT APPLICABLE FEDERAL AND LOCAL FIRE, SAFETY, ENERGY, AND ENVIRONMENTAL CODES.

Alice Holsclaw Theatre

Heathers
The Musical:
Teen Edition

atc
ARIZONA THEATRE COMPANY ACADEMY

Lighting Designer: Alex J. Alegria
LTPAlexJ@gmail.com (520) 730-4635

ATC Lighting & Projections Supervisor: Tim Smith

Director/Scenic Designer: Christopher Moseley

Production Manager/Scenic Designer: Mykel Hall

DOCUMENT REVISION HISTORY

V#	DATE	DESCRIPTION	BY
V1	06.15.2022	PRELIMINARY	AJA
V2	06.29.2022	FINAL	AJA
V3	07.23.2022	LOAD-IN/TECH	AJA

LIGHTING: MAIN

PLATE NO. **1**

PLAT DRAFTED BY: ALEX J. ALEGRIA

SCALE: 1/4" = 1'-0"

PAPER TYPE: ARCH D (24" x 36")

OF **3**

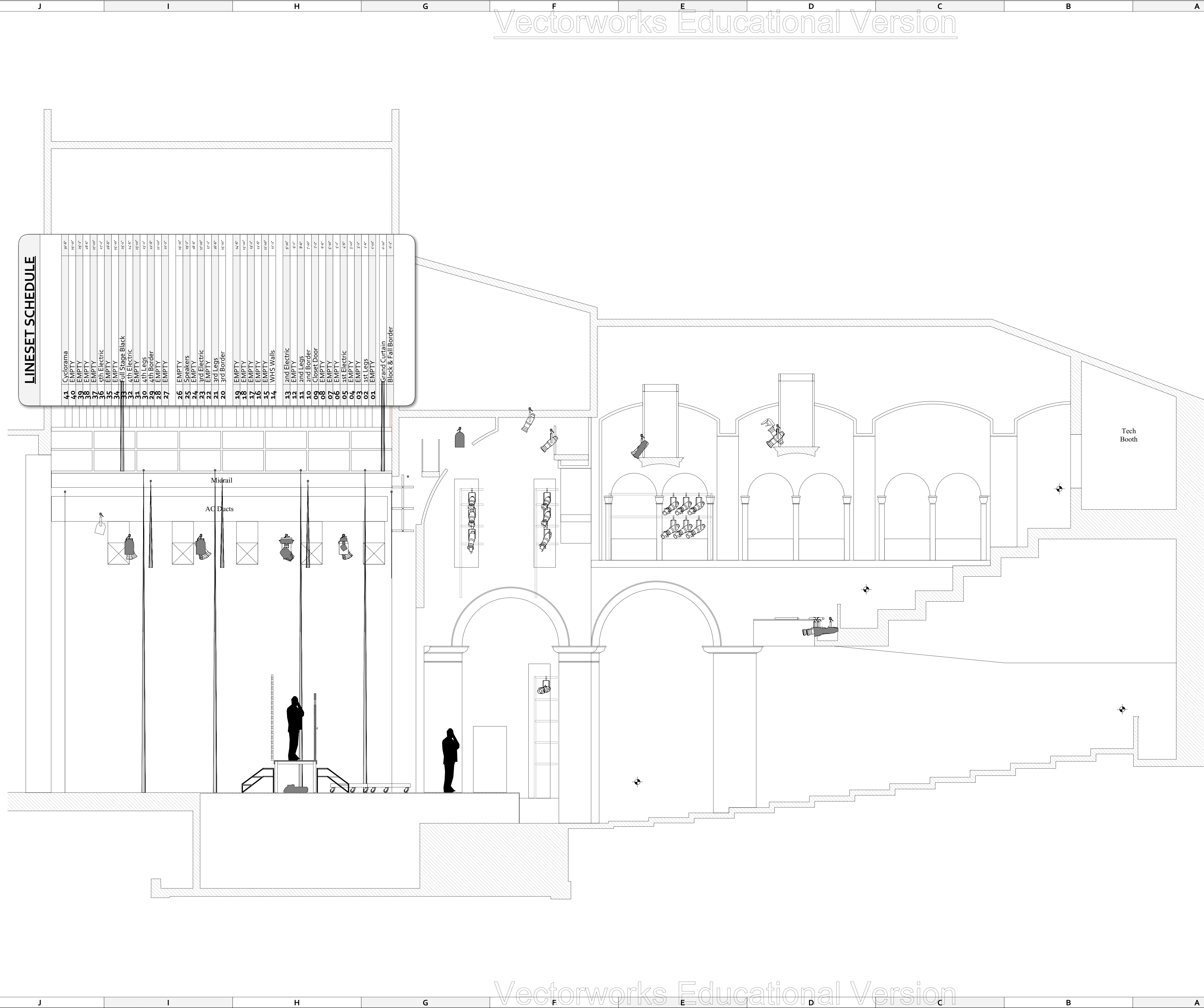

LINESET SCHEDULE

44	Cyclorama	30'0"
40	EMPTY	30'0"
39	EMPTY	30'0"
38	EMPTY	30'0"
37	EMPTY	30'0"
36	5th Electric	30'0"
35	EMPTY	30'0"
34	EMPTY	30'0"
33	Full Stage Black	30'0"
32	4th Electric	30'0"
31	EMPTY	30'0"
30	4th Legs	30'0"
29	4th Border	30'0"
28	EMPTY	30'0"
27	EMPTY	30'0"
26	EMPTY	30'0"
25	Speakers	30'0"
24	EMPTY	30'0"
23	3rd Electric	30'0"
22	EMPTY	30'0"
21	3rd Legs	30'0"
20	3rd Border	30'0"
19	EMPTY	30'0"
18	EMPTY	30'0"
17	EMPTY	30'0"
16	EMPTY	30'0"
15	EMPTY	30'0"
14	WH5 Walls	30'0"
13	2nd Electric	30'0"
12	EMPTY	30'0"
11	2nd Legs	30'0"
10	2nd Border	30'0"
09	Closet Door	30'0"
08	EMPTY	30'0"
07	EMPTY	30'0"
06	EMPTY	30'0"
05	1st Electric	30'0"
04	EMPTY	30'0"
03	EMPTY	30'0"
02	1st Legs	30'0"
01	EMPTY	30'0"
	Grand Curtain	0'0"
	Block & Fall Border	0'0"

LIGHTING INSTRUMENT/ACCESSORY KEY

SYMBOL	INSTR./ACC.	LOAD	QTY.
	Altman PAR64 MFL	1000W	(9)
	Altman PAR64 WFL	1000W	(36)
	ETC Source Four PAR WFL	575W	(4)
	ETC Source Four 10°	575W	(2)
	ETC Source Four 19°	575W	(75)
	ETC Source Four 26°	575W	(22)
	ETC Source Four 36°	575W	(32)
	Altman T-3 Cyc 3-Circuit	1500W	(10)
	ETC ColorSource PAR Deep Blue	120W	(6)
	Chauvet Rogue R1 Wash	161W	(1)
	Vari-Lite VL2500 Spot	700W	(1)
	Rosco I-Cue	17W	(1)
	City Theatrical DMX Iris	25W	(1)
	Le Maitre MVS Hazer	300W	(19)
	HES F-500 Fog Generator	1450W	(10)
	Template		(19)
	Top Hat		
	Half Hat		

COLOR & TEMPLATE SUMMARY

Color	Size	Count	Color	Size	Count
G280	10"	35	R378 & R119	6.25"	18
G645	8 1/2" x 13"	10	R334 & R119	6.25"	20
L139	8 1/2" x 13"	10			
L200 & R119	6.25"	4			
L201	6.25"	1			
L201 & R119	6.25"	1			
L201 & R119	6.25"	2			
L716	10"	35			
R02 & R08	6.25"	2			
R02 & R13	6.25"	1			
R21	10"	35			
R27	8 1/2" x 13"	10			
R34 & R119	6.25"	18			
R39 & R41	12"	1			
R51 & R119	6.25"	6			
R55 & R119	6.25"	20			
R57 & R119	6.25"	6			
R117	7.5"	6			
R305 & R119	6.25"	4			
R318 & R119	6.25"	16			

Template	Size	Count
G208	A	1
G376	A	1
G579	A	1
G585	A	2
R7725	B	2
R7724	B	16

INSTRUMENT LEGEND

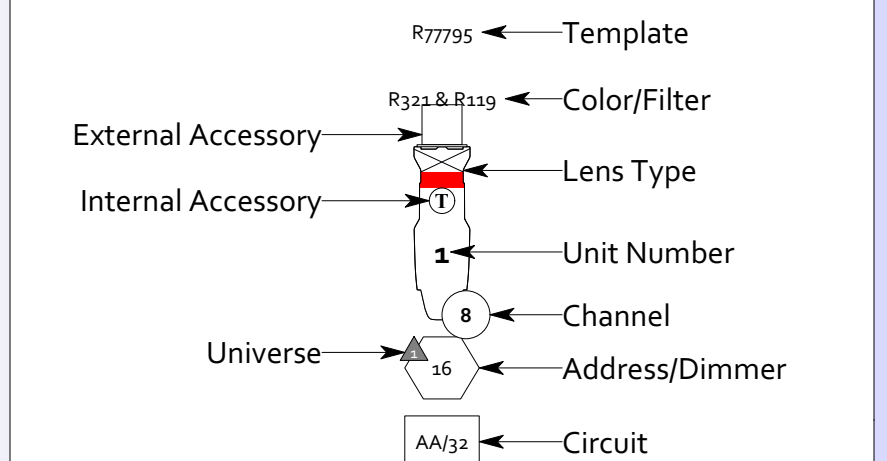

LIGHTING NOTES

- Please direct all lighting questions to the Lighting Designer or Lighting & Projections Supervisor.
- Exact placement of F-500 Fogger and MVS Hazer TBD at Load-In.
- Units on BALCONY RAIL may need to be yoked onstage.
- Ch 456 will use variegated gel; please consult with Designer.
- Please have 6x7.5" cuts each of R116 and R118 on hand for Load-In.
- Please circuit cyc lights in order and patch as 3ch Generic RGB.
- ETC ColorSource PAR Deep Blue is in 6ch [Direct] mode.
- Chauvet Rogue R1 Wash is in 39ch mode.
- Rosco I-Cue is in ch [168] mode.
- Le Maitre MVS Hazer is in 1ch mode.

ALEX J. ALEGRIA
LIGHTING DESIGN

THIS DRAWING REPRESENTS VISUAL CONCEPTS AND CONSTRUCTION SUGGESTIONS ONLY. THE DESIGNER IS UNQUALIFIED TO DETERMINE THE STRUCTURAL OR ELECTRICAL APPROPRIATENESS OF THIS DESIGN AND WILL NOT ASSUME RESPONSIBILITY FOR IMPROPER ENGINEERING, CONSTRUCTION, HANDLING, OR USE. ALL MATERIALS AND CONSTRUCTION MUST COMPLY WITH THE MOST STRINGENT APPLICABLE FEDERAL AND LOCAL FIRE, SAFETY, ENERGY, AND ENVIRONMENTAL CODES.

Alice Holsclaw Theatre

Heathers
The Musical:
Teen Edition

atc
ACADEMY

Arizona
Theatre
Company
Academy

Lighting Designer: Alex J. Alegria
LTPAlexJ@gmail.com (520) 730-4635
ATC Lighting & Projections Supervisor: Tim Smith
Director/Scenic Designer: Christopher Moseley
Production Manager/Scenic Designer: Mykel Hall

DOCUMENT REVISION HISTORY

V#	DATE	DESCRIPTION	BY
V1	06.15.2022	PRELIMINARY	AJA
V2	06.29.2022	FINAL	AJA
V3	07.23.2022	LOAD-IN/TECH	AJA

LIGHTING: SECTION VIEW

PLOT DRAFTED BY: ALEX J. ALEGRIA
SCALE: 1/4" = 1'-0"
PAPER TYPE: ARCH D (24" x 36")

PLATE NO. 2
OF 3

LIGHTING INSTRUMENT/ACCESSORY KEY

SYMBOL	INSTR./ACC.	LOAD	QTY.
	Altman PAR64, MFL	1000W	(9)
	Altman PAR64, WFL	1000W	(36)
	ETC Source Four PAR WFL	575W	(4)
	ETC Source Four 10°	575W	(2)
	ETC Source Four 19°	575W	(75)
	ETC Source Four 26°	575W	(22)
	ETC Source Four 36°	575W	(32)
	Altman T-3 Cyc 3-Circuit	1500W	(10)
	ETC ColorSource PAR Deep Blue	120W	(6)
	Chauvet Rogue R1 Wash	161W	(1)
	Vari-Lite VL2500 Spot	700W	(1)
	Rosco I-Cue	17W	(1)
	City Theatrical DMX Iris	25W	(1)
	Le Maître MVS Hazer	300W	(1)
	HES F-100 Fog Generator	1450W	(1)
	Template		(1)
	Top Hat		
	Half Hat		

COLOR & TEMPLATE SUMMARY

Color	Size	Count	Color	Size	Count
G250	10"	35	R378 & R119	6.25"	18
G645	8 1/2" x 13"	10	R334 & R119	6.25"	20
L139	8 1/2" x 13"	10			
L200 & R119	6.25"	4	Template	Size	Count
L201 & R132	12"	1	G208	A	1
L201 & R132	6.25"	2	G376	A	1
L716	10"	35	G579	A	1
R02 & R08	6.25"	2	G585	A	2
R02 & R132	6.25"	1	R7725	B	2
R21	10"	35	R7724	B	16
R22	8 1/2" x 13"	10			
R24 & R119	6.25"	18			
R39 & R41	12"	1			
R51 & R119	6.25"	6			
R55 & R119	6.25"	20			
R57 & R119	6.25"	6			
R117	7.5"	6			
R305 & R119	6.25"	4			
R318 & R132	6.25"	16			

LINESET SCHEDULE

41	Cyclorama	30' 6"
40	EMPTY	29' 10"
39	EMPTY	29' 2"
38	EMPTY	28' 6"
37	EMPTY	27' 10"
36	5th Electric	27' 2"
35	EMPTY	26' 6"
34	EMPTY	25' 10"
33	Full Stage Black	25' 2"
32	4th Electric	24' 6"
31	EMPTY	23' 10"
30	4th Legs	23' 2"
29	4th Border	22' 6"
28	EMPTY	22' 0"
27	EMPTY	21' 4"
26	EMPTY	19' 10"
25	Speakers	19' 2"
24	EMPTY	18' 6"
23	3rd Electric	17' 10"
22	EMPTY	17' 2"
21	3rd Legs	16' 6"
20	3rd Border	15' 10"
19	EMPTY	14' 6"
18	EMPTY	13' 10"
17	EMPTY	13' 2"
16	EMPTY	12' 6"
15	EMPTY	12' 0"
14	WHS Walls	11' 4"
13	2nd Electric	9' 10"
12	EMPTY	9' 2"
11	2nd Legs	8' 6"
10	2nd Border	7' 10"
09	Closest Door	7' 2"
08	EMPTY	6' 6"
07	EMPTY	5' 10"
06	EMPTY	5' 2"
05	1st Electric	4' 6"
04	EMPTY	3' 10"
03	EMPTY	3' 2"
02	1st Legs	2' 6"
01	EMPTY	2' 0"
	Grand Curtain	0' 10"
	Block & Fall Border	0' 2"

INSTRUMENT LEGEND

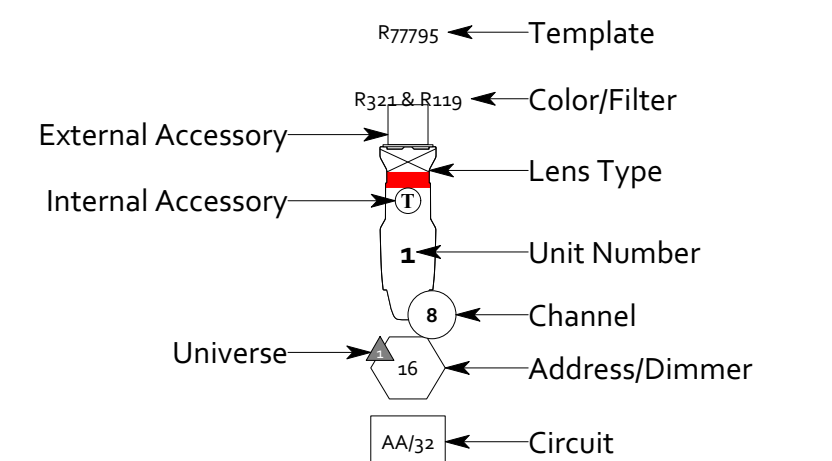

LIGHTING NOTES

- Please direct all lighting questions to the Lighting Designer or Lighting & Projections Supervisor.
- Exact placement of F-100 Fogger and MVS Hazer TBD at Load-In.
- Units on BALCONY RAIL may need to be yoked onstage.
- Ch 456 will use variegated gel; please consult with Designer.
- Please have 6x7.5" cuts each of R116 and R118 on hand for Load-In.
- Please circuit cyc lights in order and patch as 3ch Generic RGB.
- ETC ColorSource PAR Deep Blue is in 6ch [Direct] mode.
- Chauvet Rogue R1 Wash is in 3ch mode.
- Rosco I-Cue is in ch [168] mode.
- Le Maître MVS Hazer is in 1ch mode.



ALEX J. ALEGRIA LIGHTING DESIGN

THIS DRAWING REPRESENTS VISUAL CONCEPTS AND CONSTRUCTION SUGGESTIONS ONLY. THE DESIGNER IS UNQUALIFIED TO DETERMINE THE STRUCTURAL OR ELECTRICAL APPROPRIATENESS OF THIS DESIGN AND WILL NOT ASSUME RESPONSIBILITY FOR IMPROPER ENGINEERING, CONSTRUCTION, HANDLING, OR USE. ALL MATERIALS AND CONSTRUCTION MUST COMPLY WITH THE MOST STRINGENT APPLICABLE FEDERAL AND LOCAL FIRE, SAFETY, ENERGY, AND ENVIRONMENTAL CODES.

Alice Holsclaw Theatre



Lighting Designer: Alex J. Alegria
 LTPAlexJ@gmail.com (520) 730-4635
 ATC Lighting & Projections Supervisor: Tim Smith
 Director/Scenic Designer: Christopher Moseley
 Production Manager/Scenic Designer: Mykel Hall

DOCUMENT REVISION HISTORY

V#	DATE	DESCRIPTION	BY
V1	06.15.2022	PRELIMINARY	AJA
V2	06.29.2022	FINAL	AJA
V3	07.23.2022	LOAD-IN/TECH	AJA

LIGHTING: FOCUS POINTS

PLATE NO. **3**

PLOT DRAFTED BY: ALEX J. ALEGRIA

SCALE: 1/4" = 1'-0" PAPER TYPE: ARCH D (24" x 36") OF 3